

Atlas Copco Surface Drill Rigs

AirROC T25 / D40 (ROC 203)

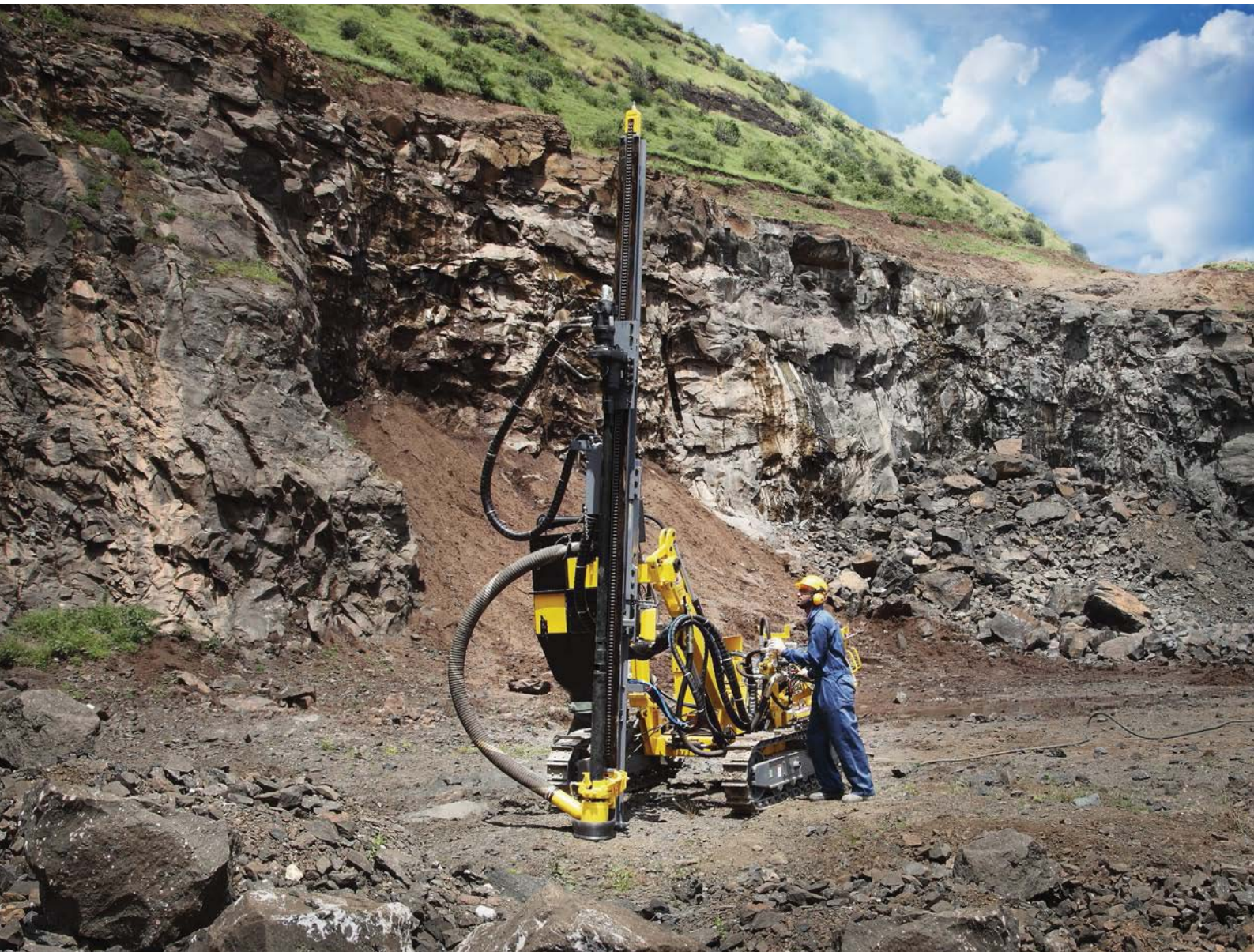

Hole range : 48 - 76 mm - AirROC T25
89 - 115 mm - AirROC D40

Sustainable Productivity

Atlas Copco

Features and technical information

For further information, please contact your local Atlas Copco Customer Center.

A highly adaptable drilling rig well known for its versatility and ease of use the AirROC T25 / D40* is an ideal choice for construction, mining or quarry work where approaches or terrain present operational challenges. With its reliable lightweight design and independent track oscillation system this robust pneumatic rig delivers proven reliability in the most challenging of terrain.

The AirROC T25 / D40* is equipped with a feed re-pinning mechanism for toe-hole and horizontal drilling operations. An optional conversion kit offers 'Down-the-Hole' or 'Top Hammer' versatility. An independent track oscillation system powered by hydraulic motors and a planetary gear drive provides excellent traction on undulating terrain.

- AirROC T25* is equipped with BBC120F drifter for Top Hammer Application (48mm-76mm hole dia)
- AirROC D40* is a Down The Hole drill with BBR4 Rotation unit (89mm-115mm)

*Formerly known as ROC 203 range of products

Drill coverage area

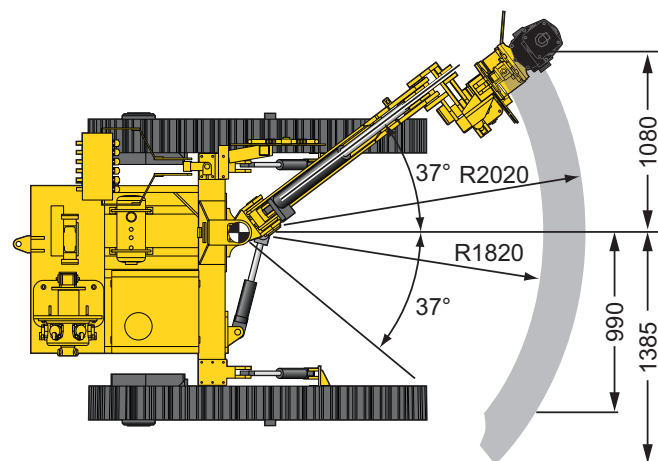

Horizontal reach (mm)



Technical data

Carrier		
Tramming speed, max	3.2 km/h	2 mph
Track oscillation	±12°	
Steel feed		
AirROC T25		
Feed extension	800 mm	31.5"
Feed rate, max	0.3 m/s	59 ft/min
Feed force, max	8 kN	1 798 lbf
Tractive pull, max	5 kN	1 124 lbf
Total length	5 450 mm	214.6"
Travel length	3 940 mm	155"
AirROC D40		
Feed extension	800 mm	31.5"
Feed rate, max	0.3 m/s	59 ft/min
Feed force, max	8 kN	1 798 lbf
Tractive pull, max	5 kN	1 124 lbf
Total length	5 450 mm	214.6"
Travel length	4 009 mm	157.8"
Drill tube / Rod size		
Drill rig	Pipe size	
AirROC T25	32, 38 mm	1.25", 1.75"
AirROC D40	76 mm	3"
Transport dimensions		
Transportation position		
Height	1 780 mm	70"
Length	5 450 mm	215"
Width	1 880 mm	74"
Weight		
AirROC T25	2 480 kg	5 467 lb
AirROC D40	2 515 kg	5 545 lb

Legal Notice © Copyright 2010, Atlas Copco Rock Drills AB, Örebro, Sweden. All product names in this publication are trademarks of Atlas Copco. Any unauthorized use or copying of the contents or any part thereof is prohibited. Illustrations and photos may show equipment with optional extras. No warranty is made regarding specifications or otherwise. Specifications and equipment are subject to change without notice. Consult your Atlas Copco Customer Center for specific information.